

ASHLAND CONVEYOR PRODUCTS

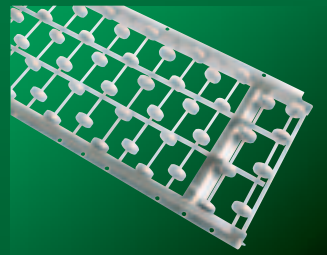

Belt Conveyors



Skatewheels

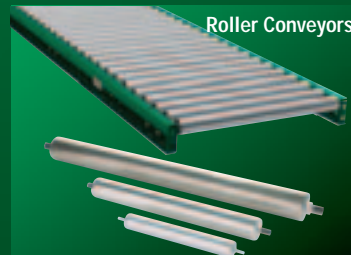

Roller Conveyors

Replacement Rollers



Floor Supports



Telescoping Conveyors



Ball Tables

Accessories

Catalog No. CT102

Roller Conveyor

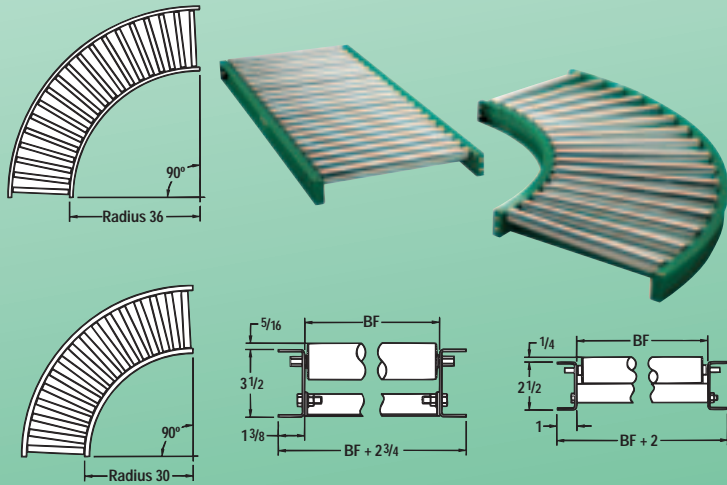

Light Duty

Frame - 1" x 2-1/2" x 1" x 12 Ga. Galv. Steel Frame with Hook & Rod Couplers. 36" I.R. Curves

Rollers - 1-3/8" x 18 Ga. Galv. Steel Rollers with 1/4" Round Spring Retained Plain Steel Shafts.

B.F.	Length	Part #	Roll Centers	Lbs/Section
10"	5' Long	11F05EG15B10	1.5"	51
10"	5' Long	11F05EG03B10	3"	34
10"	10' Long	11F10EG15B10	1.5"	101
10"	10' Long	11F10EG03B10	3"	67
10"	90° Curve	11F90EG15B10	1.5"	53
16"	5' Long	11F05EG15B16	1.5"	69
16"	5' Long	11F05EG03B16	3"	43
16"	10' Long	11F10EG15B16	1.5"	137
16"	10' Long	11F10EG03B16	3"	85
16"	90° Curve	11F90EG15B16	1.5"	71
22"	5' Long	11F05EG15B22	1.5"	86
22"	5' Long	11F05EG03B22	3"	52
22"	10' Long	11F10EG15B22	1.5"	171
22"	10' Long	11F10EG03B22	3"	103
22"	90° Curve	11F90EG15B22	1.5"	88

Slider Bed Belt Conveyor

4" Deep Formed Channel Frame PVC 120 Belting
H-Stands for 27" to 34" to top of belt. 1/2 HP
115/208-230 VAC Single Phase Motor Pre-wired with
On/Off Switch. 4" diameter Head and Tail Pulleys with
Take-ups. 60 FPM fixed belt speed.

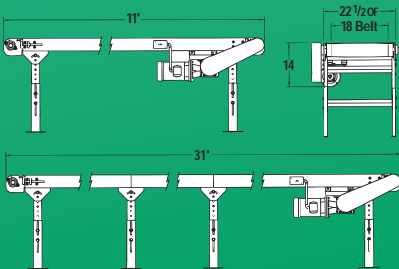

Overall Length	Part #	Belt Width	Bed Width	Load Cap.	Weight
11'	SB40011B18	18"	22.5"	335#	425#
21'	SB40021B18	18"	22.5"	319#	625#
31'	SB40031B18	18"	22.5"	302#	820#

Medium Duty

Frame - 1-3/8" x 3-1/2" x 1-3/8" x 11 Ga. with End Plate Couplers

Finish - Powder Coated Ashland Green. 30" I.R. Curves

Rollers - 1.9" x 16 Ga. Galv. Steel Rollers with
7/16" Hex Spring Retained Plain Steel Shafts.

B.F.	Length	Part #	Roll Centers	Lbs/Section
10"	5' Long	10F05KG03B10	3"	66
10"	5' Long	10F05KG06B10	6"	47
10"	10' Long	10F10KG03B10	3"	131
10"	10' Long	10F10KG06B10	6"	93
10"	90° Curve	3F90KG03B10	3"	59
16"	5' Long	10F05KG03B16	3"	86
16"	5' Long	10F05KG06B16	6"	58
16"	10' Long	10F10KG03B16	3"	171
16"	10' Long	10F10KG06B16	6"	115
16"	90° Curve	3F90KG03B16	3"	79
22"	5' Long	10F05KG03B22	3"	106
22"	5' Long	10F05KG06B22	6"	68
22"	10' Long	10F10KG03B22	3"	211
22"	10' Long	10F10KG06B22	6"	137
22"	90° Curve	3F90KG03B22	3"	99
36"	5' Long	10F05KG03B36	3"	153
36"	5' Long	10F05KG06B36	6"	94
36"	10' Long	10F10KG03B36	3"	306
36"	10' Long	10F10KG06B36	6"	188
36"	90° Curve	3F90KG03B36	3"	146



**Ball Transfer
Drop-In Plates**

Converts any (Rollers High) Light or Medium Duty Ashland Roller Conveyor into a Ball Transfer Section. 12 Ga. Galv. Steel 75# capacity Ball Transfers set high on 3" centers. (Note: plates are punched on 1" CL).

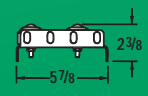
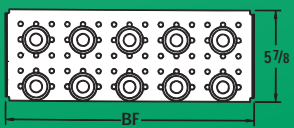

Model #	Length	B.F.	Weight
BTI1003	6"	10"	5#
BTI1603	6"	16"	8#
BTI2203	6"	22"	11#
BTI3603	6"	36"	16#

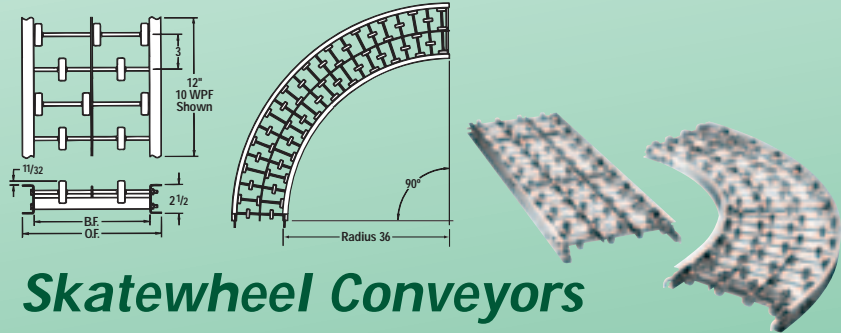

Skatewheel Conveyors

Overall Width O.F.	Length	Part #	Frame	Wheels Per Ft	Lbs./ Section
12"	5'	12X10X05G	2.5" x 12 ga Galv Steel	10 WPF	33#
12"	5'	12X10X05A	2.5" x 1/8" Aluminum	10 WPF	19#
12"	10'	12X10X10G	2.5" x 12 ga Galv Steel	10 WPF	64#
12"	10'	12X10X10A	2.5" x 1/8" Aluminum	10 WPF	36#
12"	90 Deg	12X10X90G	2.5" x 12 ga Galv Steel	10 WPF	35#
12"	90 Deg	12X10X90A	2.5" x 1/8" Aluminum	10 WPF	21#
18"	5'	18X16X05G	2.5" x 12 ga Galv Steel	16 WPF	43#
18"	5'	18X16X05A	2.5" x 1/8" Aluminum	16 WPF	26#
18"	10'	18X16X10G	2.5" x 12 ga Galv Steel	16 WPF	85#
18"	10'	18X16X10A	2.5" x 1/8" Aluminum	16 WPF	50#
18"	90 Deg	18X16X90G	2.5" x 12 ga Galv Steel	16 WPF	48#
18"	90 Deg	18X16X90A	2.5" x 1/8" Aluminum	16 WPF	29#
24"	5'	24X20X05G	2.5" x 12 ga Galv Steel	20 WPF	52#
24"	5'	24X20X05A	2.5" x 1/8" Aluminum	20 WPF	32#
24"	10'	24X20X10G	2.5" x 12 ga Galv Steel	20 WPF	103#
24"	10'	24X20X10A	2.5" x 1/8" Aluminum	20 WPF	61#
24"	90 Deg	24X20X90G	2.5" x 12 ga Galv Steel	20 WPF	59#
24"	90 Deg	24X20X90A	2.5" x 1/8" Aluminum	20 WPF	37#

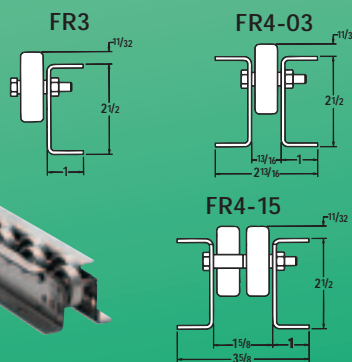
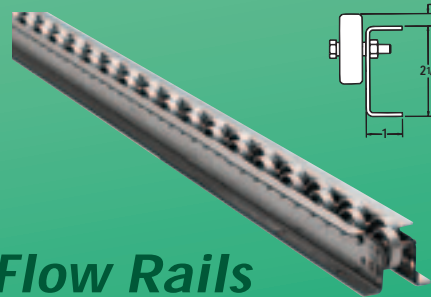

Flow Rails

Frame- 1" x 2-1/2" x 1" x 12 ga. Galv. Steel Channel w/notched ends.
Wheels- 75# or 100# Capacity 1-15/16" Diameter Galv. Steel.

Length	Part #	Single or Double Channel	Wheel Capacity	Wheel Centers	Lbs./ Section
5'	05FR37503	FR3	75#	3"	13
10'	10FR37503	FR3	75#	3"	25
5'	05FR310003	FR3	100#	3"	14
10'	10FR310003	FR3	100#	3"	28
5'	05FR47503	FR4-03	75#	3"	20
10'	10FR47503	FR4-03	75#	3"	40
5'	05FR410003	FR4-03	100#	3"	22
10'	10FR410003	FR4-03	100#	3"	43
5'	05FR47515	FR4-15	75#	1.5"	16
10'	10FR47515	FR4-15	75#	1.5"	49
5'	05FR410015	FR4-15	100#	1.5"	27
10'	10FR410015	FR4-15	100#	1.5"	54

Replacement Rollers

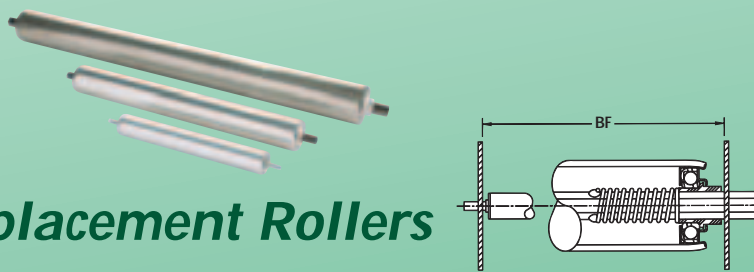

Model# /Part#	BF Range	Size	Material	Spring Retained Shaft Size (Plain Steel)	Roller Capacity @ 10" BF
BB_ _ *	06" to 22"	3/4" x 20 Ga	Plain Steel	1/4" Round	42#
EA_ _ *	06" to 22"	1-3/8" x 18 Ga	Aluminum	1/4" Round	94#
EG_ _ *	06" to 22"	1-3/8" x 18 Ga	Galv Steel	1/4" Round	94#
EFA_ _ *	06" to 22"	1-3/8" x 18 Ga	Aluminum	5/16" Hex	94#
EFG_ _ *	06" to 22"	1-3/8" x 18 Ga	Galv Steel	5/16" Hex	94#
C_ _ *	06" to 36"	1-3/8" x 16 Ga	Galv Steel	7/16" Hex	396#
KA_ _ *	06" to 36"	1.9" x 16 Ga	Aluminum	7/16" Hex	270#
KG_ _ *	06" to 51"	1.9" x 16 Ga	Galv Steel	7/16" Hex	270#
DD_ _ *	06" to 51"	1.9" x 12 Ga	Galv Steel	7/16" Hex	270#
KD_ _ *	06" to 51"	1.9" x 9 Ga	Plain Steel	7/16" Hex	850#
UA_ _ *	06" to 51"	2-1/2" x 14 Ga	Plain Steel	7/16" Hex	290#
S_ _ *	06" to 77"	2-1/2" x 11 Ga	Plain Steel	11/16" Hex	850#
T_ _ *	06" to 77"	2-5/8" x 7 Ga	Plain Steel	11/16" Hex	850#

* Replace _ _ with full inch BF dimension. Example: BB06 = 6"BF 3/4" x 20 Ga.

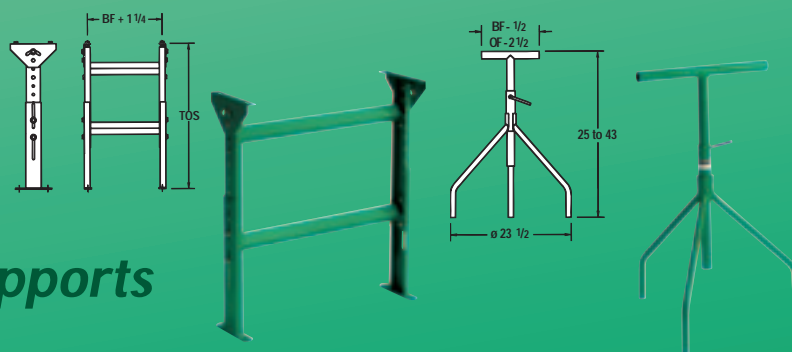

Supports

Finish - Powder Coated Ashland Green, Steel Construction

Style	Fits BF	Part #	Capacity	Top of Stand Range	Stand Weight
Tripod	10"	DT12S25T43	400 #	25" - 43"	9.5#
H-Stand	10"	HB15M25B10	1500 #	19.5" - 31"	15#
H-Stand	10"	HB15M37B10	1500 #	31" - 43"	18#
H-Stand	10"	HB15M49B10	1500 #	43" - 55"	21#
Tripod	16"	DT18S25T43	400 #	25" - 43"	15.5#
H-Stand	16"	HB15M25B16	1500 #	19.5" - 31"	17#
H-Stand	16"	HB15M37B16	1500 #	31" - 43"	20#
H-Stand	16"	HB15M49B16	1500 #	43" - 55"	23#
Tripod	22"	DT24S25T43	400 #	25" - 43"	21.5#
H-Stand	22"	HB15M25B22	1500 #	19.5" - 31"	19#
H-Stand	22"	HB15M37B22	1500 #	31" - 43"	22#
H-Stand	22"	HB15M49B22	1500 #	43" - 55"	25#
H-Stand	36"	HB15M25B36	1500 #	19.5" - 31"	23#
H-Stand	36"	HB15M37B36	1500 #	31" - 43"	26#
H-Stand	36"	HB15M49B36	1500 #	43" - 55"	29#

Accessories

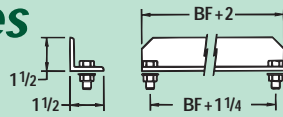

Angle Iron End Stops

1-1/2" x 1-1/2" x 3/16" Painted Steel
Finish - Powder Coated Ashland Green



Part #	Fits B.F.	Weight
AS190B10	10"	2 #
AS190B16	16"	3 #
AS190B22	22"	4 #
AS190B36	36"	6 #

Fixed Channel Guards

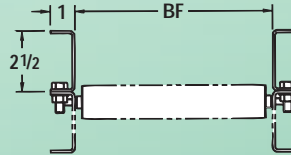

1" x 2-1/2" x 12 Ga. Galv. Steel Guard
(1) Pair both Inner and Outer Guards

Part #	Fits Conveyor	BF	Weight
GU390B10R36	90 Deg Skwl & Light Roll	10"	15#
GU390B16R36	90 Deg Skwl & Light Roll	16"	16#
GU390B22R36	90 Deg Skwl & Light Roll	22"	18#
GU390B10R30	90 Deg Med Duty Roller	10"	13#
GU390B16R30	90 Deg Med Duty Roller	16"	14#
GU390B22R30	90 Deg Med Duty Roller	22"	15#
GU390B36R30	90 Deg Med Duty Roller	36"	18#
GU305	Any 5' Straight Pair	Any	18#
GU310	Any 10' Straight Pair	Any	36#

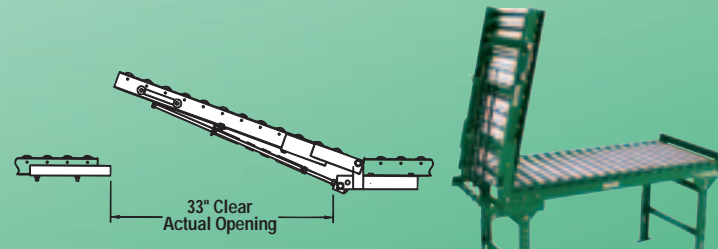

3' Long Spring Hinge Gate

3' Long (33" Opening) Spring Assist Gate Sections
Conveyor Section Included, H-Stands sold separately.
Finish - Powder Coated Ashland Green

Part #	Fits Conveyor	BF	Weight
HG1210A03	12 x 10 Alum. Skwl	10"	37#
HG1210G03	12 x 10 Galv. Skwl	10"	47#
HG140B1003	Light Duty Roller	10"	59#
HG190B1003	Med Duty Roller	10"	70#
HG1816A03	18 x 16 Alum. Skwl	16"	43#
HG1816G03	18 x 16 Galv. Skwl	16"	58#
HG140B1603	Light Duty Roller	16"	72#
HG190B1603	Med Duty Roller	16"	87#
HG24X20A03	24 x 20 Alum. Skwl	22"	49#
HG24X20G03	24 x 20 Galv. Skwl	22"	66#
HG140B2203	Light Duty Roller	22"	87#
HG190B2203	Med Duty Roller	22"	103#

NEED HELP SELECTING A CONVEYOR?

Provide us with the following information and we can get started:

WHAT?...

...is the package size?

Smallest: L___ W___ H___ Lbs.____

Largest: L___ W___ H___ Lbs.____

...does the conveying surface look like?

How?...

...are they loading/unloading?

...Many products are on the conveyors?

...high is the conveying surface?

WHERE?...

...are the conveyors being used (environment)?

...do you want to move the products from point "A" to point "B" by means of gravity, power or manually?

Ashland Conveyor Products

1-800-587-0045

Fax: 419-281-1076

www.ashlandconveyor.com



ASHLAND CONVEYOR PRODUCTS



Authorized Distributor

Ashland Conveyor Products

1374 Enterprise Parkway • Ashland, OH 44805 • 1-800-587-0045 • Fax: 419-281-1096

www.ashlandconveyor.com